

# OPERATOR'S MANUAL



**Envirotecnics Global Service SL**

**Oficinas y Fabricación:** Calle dels Pirineus s/n  
(esquina Espinau) 17460 - Celrà - Girona Tel: 872  
080 542 Fax: 872 080 543 **Delegación Madrid:**  
Avda. de Castilla 28 - 28830 - Tel: 916 780 039  
Servicio al cliente:

[envirotecnics@envirotecnics.com](mailto:envirotecnics@envirotecnics.com)

[www.envirotecnics.com](http://www.envirotecnics.com)



## 30 DAY LIMITED FACTORY WARRANTY

FULTZ PUMPS, INC. sampling pump units are warranted to be free from defects in material and/or workmanship for a period of thirty (30) days from date of shipment. The pump head is warranted to be free from defects in material and/or workmanship for one (1) year from date of shipment. All requests for warranty service must be received during the warranty period. Should any unit fail during the warranty period due to faulty material and/or workmanship, it will be repaired at the factory or replaced at the option of Fultz Pumps, Inc. All units returned for any warranty claim must obtain prior factory authorization and shall be shipped freight prepaid. COD shipments WILL NOT be accepted. The liability of Fultz Pumps, Inc. is limited exclusively to repair or replacement of defective units. Under no circumstances shall Fultz Pumps, Inc. be liable for consequential damages of any kind. It shall be the user's responsibility to insure the suitability of the unit for any intended use, purpose, or application. In addition, the following items not covered by this warranty shall include but are not limited to:

- Expendable items such as rotors, tubing, etc.
- Damage due to misuse, carelessness, abuse, accidents, negligence, corrosion, etc.
- Suitability for specific purpose, use or application.
- Any alteration of any kind.
- Unauthorized repair.

This represents the total of all responsibilities obligated by this warranty.

## FOREWORD

The information presented in this instruction manual has been compiled to provide the operator with a thorough understanding of the capabilities and operation of the unit. It is strongly recommended that this manual be read carefully with all cautions noted and observed before placing the equipment in service.

Every effort has been made to make operation of the unit as simple, reliable, and trouble free as possible. Should a malfunction occur, consult the troubleshooting chart for possible causes and/or corrective measures. If the problem persists, call or write the service department at:

FULTZ PUMPS, INC.  
P.O. BOX 550  
LEWISTOWN, PA 17044  
USA

PHONE 717-248-2300  
FAX 717-248-5458  
e-mail info@fultzpumps.com

It may be possible to diagnose minor problems over the phone, however if it should be necessary to return equipment to the factory for service, please follow the shipping instructions provided by the service department.

TABLE OF CONTENTS

INTRODUCTION 4

PUMP HEAD 5

CONTROL PANEL 6

DUAL PVC POWER WIRE 7

HOSE REEL 8

HOSE 8

FRAME 9

POWER SUPPLY OPTIONS 9

TESTING THE PUMP (IN-HOUSE) 11

FIELD USE 12

MAINTENANCE 13

TROUBLESHOOTING 14

PUMP DIAGRAM 15

WARRANTY INFORMATION 17

ITEM NO.	PART NO.	QTY.	TITLE	DESCRIPTION
1	007	1	ADAPTER, QUICK CONNECT	+
2	181	1	TERMINAL, HOT LEAD	+
3	059	5	SCREW FILLISTER HD.	6-32 UNF x 1/2 LG.
4	015	1	SCREEN, INLET	
5	046	1	ADAPTER, INLET-OUTLET	+
6	307	1	ROTOR, IDLER	+
7	308	1	ROTOR, DRIVEN	+
8	047	1	GLAND, PACKING	
9	061	1	SEAL, O-SECTION	
10	302	1	HEAD ASSY., PUMP	+
11	062	1	SEAL, O-SECTION	
12	309	3	RING, RETAINER	WM.BERG 1/1N Q2-25
13	310	1	RETAINER, SEAL	+
14	311	1	SEAL, O-SECTION	
15	312	1	SEAL, CARBON	
16	313	1	SEAT, SEAL	+
17	314	1	SEAL, O-SECTION	
18	178	84	WASHER, BELLEVILLE	
19	320	2	BEARING	SR 188 SS.
20	305	2	BRUSH HOLDER ASSY.	+
21	321	2	BRUSH	
22	322	4	SCREW, SLOTTED HD.	4-40 UNF x 1/4 BRASS
23	303	1	ARMATURE	+
24	316	1	FIELD, PM	+
25	323	1	END, BELL	+
26	324	2	BOLT, HEX HD.	+
27	325	1	COVER ASSY.	+



REF. ITEM #18  
SEQ. FOR STACKING

MATL.	SCALE	TITLE	PAGE 2 OF 2
FULTZ PUMPS INC.		PUMP ASSY., 300	PART NO. 300

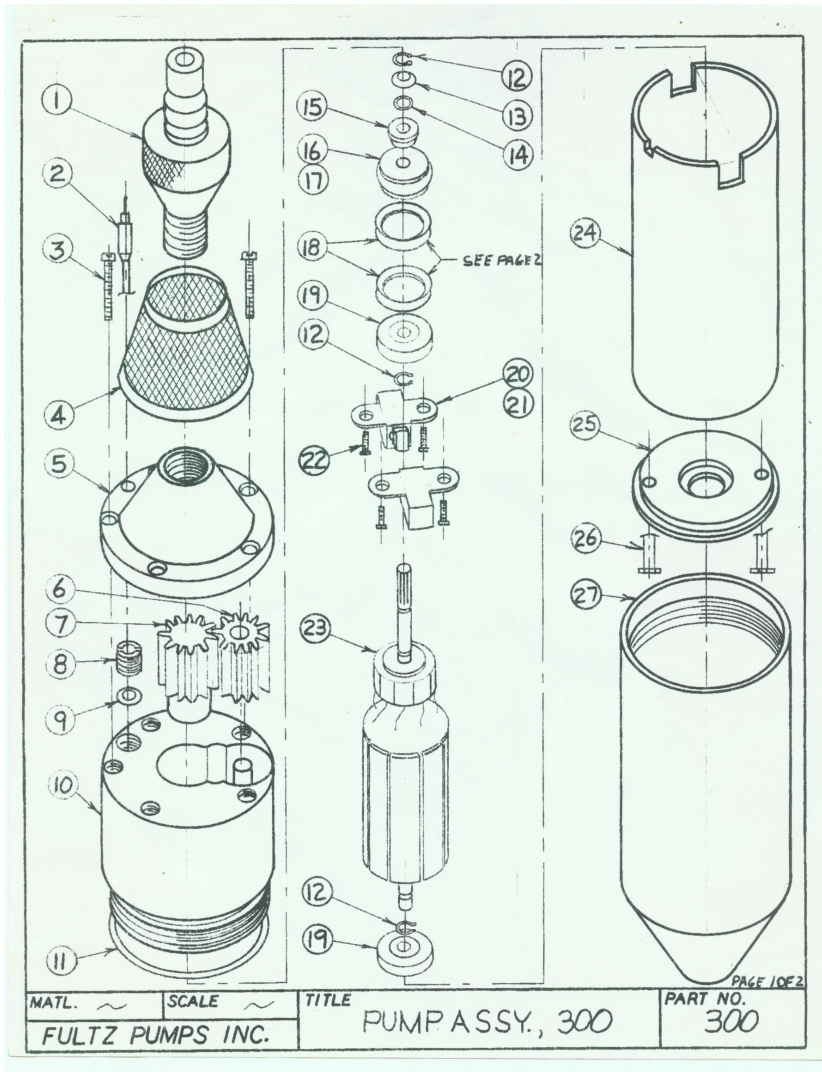

15

## INTRODUCTION

The Fultz Pumps, Inc. line of sampling pump systems have been developed to provide field personnel with a compact portable, self contained unit for the convenient collection of samples from groundwater monitoring wells or similar devices.

4



## PUMP HEAD

The Fultz Pump Inc. line of pumps operate on the principle of positive displacement. Water is introduced into the pump through a 60 mesh screen into a stainless steel cavity. Two Teflon\* gears or “rotors” inside the cavity displace the water up through the hose in a steady stream. Teflon\* is used in the interest of purity, however this is the wear item on the pump head and the only thing to require routine maintenance. Rotors are field replaceable, approximately 100 hours of pumping time can be expected from a set of rotors in clear water, however suspended solids will affect the life of these rotors. We recommend the operator always keep a spare set of new rotors on hand. The pump’s electric motor runs on 36V DC power. The pump head specifications are as follows:

	<u>SP-300 Pump Head</u>
	<u>SP-400 Pump Head</u>
Diameter:	1.75”
Length:	9.16”
Weight:	2.5 lbs.
Materials:	304 Stainless Steel Teflon* rotors Viton housing seal Carbon motor seal
Performance:	1.4 GPM @150’

\*Teflon is a registered trademark of E.I. DuPont.

## TROUBLESHOOTING CHART

Problem	Possible Cause	Remedy
No power to pump	-Battery pack low -Power lead broken -Internal wire dis- Connected -Water leakage into Motor	-Recharge -Repair/Resolder -Connect/Repair wire -Return to factory
Pump output reduced	-Hose kinked -Rotors worn -Screen clogged -Power Supply low -Water high in sus- pended solids	-Straighten hose -Replace rotors -Pump in reverse -Recharge batteries -Allow solids to settle
High amp reading	-Pump out of water -Sediment in pump -New rotors	-Submerge -Clean rotor cavity -Break in rotors per instructions
Batteries refuse to Accept a charge	-Dead battery cell -Loose battery wire	-Test cells individually -Tighten connection

Should the battery supply fail to take/hold a charge, a dead cell may be responsible. Individual cells of the pack may be tested with a 6V, 2amp automotive bulb test light. Dead cells can sometimes be restored by charging individually. To charge a cell, remove the cell from pack and place on 6V charger. Charge at 6-8 amps until amp meter reads 1-1.9 amps. **Do not exceed 2 amps.** Replace battery as first cell in series and charge pack through normal cycle. If power supply is not sufficient, replace dead cell battery.

Contact factory service dept. to troubleshoot any other problems. Pump should be returned to factory for any internal problems. User repairs have proven unsuccessful. Factory service is reasonable and prompt.

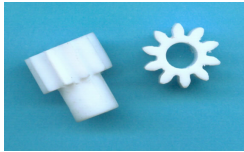

## MAINTENANCE

Replacement of rotors is the only routine maintenance normally required. To replace rotors, disconnect the pump from the hose, Unscrew the quick connect coupling from the pump and lift off the screen. Remove the screws that hold the pump inlet cone down. Rotate the inlet cone on the hot lead wire being careful not to damage the insulation on the wire. With a pair of needle nose pliers, firmly grip each rotor by a tooth and pull up. Do not pry rotors out with a screwdriver as this will raise a burr on the edge of the pump cavity preventing the proper metal to metal seal that is necessary to maintain pressure and lift. Place new “drive” rotor on motor shaft and align rotor splines with splines on the shaft. Press gently onto the shaft with thumb being careful not to shave sides of rotor on pump cavity. Install the inlet cone and use the five screws to finish drawing the rotor down onto the shaft. Then loosen the five screws ½ turn each and run pump in a container of clear water. NOTE: SPEED CONTROL MUST BE SET ON HIGH. Gradually re-tighten the 5 screws until the rotor runs free. Remove the pump inlet cone again and install the other “driven” rotor into the pump cavity aligning teeth with drive rotor. Replace pump inlet cone and tighten screws. Back off screws ½ turn and run pump in container of clear water. Gradually re-tighten screws with pump running to de-burr rotors for proper seating and best performance.

We recommend that you occasionally remove the pump’s cover and check for moisture. A leak detected early can minimize any necessary repairs. Unscrew the gray casing on the bottom of the pump being careful not to drop this threaded casing. The motor section should be dry. If there is more than a teaspoon of water in the motor section, the pump needs to be returned for service. If less than a teaspoon, leave the cover off and allow to dry overnight.

13



## CONTROL PANEL

**Forward/Off/Reverse Switch** - This 3 way switch is used to select which direction the pump is running or turn the power off to the pump. Reverse is only to be used momentarily to clear any debris that may have collected around the pump’s screen during purging/sampling, or to drain the hose once purging/sampling is completed. **Always turn power off before changing direction of pump or damage to the unit may result**

**Amp Meter** - Displays the amperage drawn by the pump. The model SP-300 and SP-400 pumps should draw between 3.5 and 4.5 amps. If the meter is reading 5+ amps, turn the power off and refer to troubleshooting guide or call Fultz Pumps, Inc. for assistance.

**Breaker Switch** - Installed to protect the pump motor. Should the pump encounter any difficulty pumping and draw 5+ amps, the breaker switch will turn the system off. The switch is normally black, however if it is activated, the lower section will be white. If this should happen, wait 2 minutes for the system to cool and press the switch back down again to initialize. Refer to the troubleshooting guide to find out what may have caused the pump to draw high amperage. **Never try to override the breaker switch by holding it down.**

6

DC Plug - This jack is for an optional 36V DC battery pack.

Power In / AC or DC - This switch is to select between using the internal AC power supply or an external DC battery source plugged into the DC jack.

Flow Rate Knob - Controls the pumping speed. This is convenient when changing from high flow rate for purging to lower flow rates for sampling. Use caution when slowing the flow rate down so as not to stall the pump and cause the motor to burn up by leaving it under power in a stalled position. If the pump should stall, the amp meter will jump about 1/3 amp. The best way to avoid this is to not stop the flow entirely. **Always start the pump with the flow rate set to full speed.**

## DUAL PVC POWER WIRE

This wire assembly is used primarily with the customer's own disposable tubing. The upper end of the wire has a white rectangular waldom plug installed. This mates to the wire from the control briefcase. The lower end of this wire has 2 terminations. The molded watertight plug mates to the red wire on the top of the pump. The ring terminal side of the lower end serves as an electrical ground. This is secured under the screw on the side of the stainless steel female quick connect coupling inserted into your tubing. Remove this screw and place the ring terminal under the screw and tighten the screw back down. Use caution handling the screw because it is small.

7

## FIELD USE

Before placing the pump in the well, establish water levels and well depths for each sampling location. This is necessary to ensure both accurate records as well as minimizing possibility of immersing pump head in mud/sediment at the bottom of the well. Pumping liquids containing silt, sand, or other abrasive suspended solids will result in premature wear of the rotors. The unit is designed for clear water pumping and proper equipment care is essential for maximum service life.

### 2 Inch Well

6' Section of well contains approximately 1 gallon of water

### 4 Inch Well

18" Section of well contains approximately 1 gallon water

- Attach pump and hose quick connect couplings.
- Attach pump and hose watertight electrical connections. Prevent excess wire from snagging on well casing by twisting the pump on the end of hose to coil excess wire around hose.
- Lower pump into well to desired depth being careful not to kink the hose or scrape it on the edge of the casing.
- Select power supply setting on controller (AC/DC switch)
- Set Flow Rate knob to full speed.
- Place Forward/Off/Reverse switch in forward position.
- Observe sound of pump operation and amp meter reading to insure pump is within specified operating limits. **Do not run pump dry.**
- Adjust Flow Rate knob if needed.

Turn off power once purging/sampling is complete. If not using a check valve to keep the water from draining back down the hose and into the well, we recommend running pump in Reverse momentarily to drain the hose.

12

## TESTING THE PUMP (IN-HOUSE)

- Attach pump head and hose quick connect couplings
- Attach pump head and hose watertight electrical connections.
- Immerse pump head in sink, bucket or other adequate supply of clean cold water. Make sure inlet screen is completely covered. **Do not run pump dry. Water provides lubrication for the rotors.**
- Connect Power Supply
- Set Flow Rate knob to full speed.
- Place Forward/Off/Reverse switch to Forward position

Observe amp meter reading. Amperage drawn for normal operation is 3.5 to 4.5 amps. Shut off immediately if amp meter reads 5+ amps and consult troubleshooting section. New rotors will generally draw higher amperage readings until they are broken in. In no case should the pump be operated at higher than 5 amps.

## HOSE REEL

A composite hose reel is supplied with the rotating reel model. Reel capacity is 200' of polyethylene hose or 300' of Teflon\* hose. Brass slip rings in the hub of the reel allow the pump to be run while raising or lowering the pump depth or locked into a stationary position. The hose/reel assembly can easily be removed should the operator wish to change hoses. To remove the hose/reel assembly, use a snap ring tool to remove the snap ring on the hub of the reel. Slide the gray PVC spacer off the hub (be careful not to lose the spacer). Slide the hose/reel off.

## HOSE

The hose with integrated wire is both easy to handle, and easy to decon. This hose is available in both polyethylene and Teflon\* lined polyethylene. Standard hose length is 100', however hoses can be made to any length specified. Extension hoses can also be ordered to any length. Quick connect couplings made of stainless steel and pvc watertight electrical connections are installed.

## LIGHTWEIGHT WIRE REEL

Tightening the handle on the hub of the reel locks it once the pump has been lowered to the desired depth.



## FRAME

The freestanding tubular frame is designed so one person can easily and comfortably lift and transport the unit.

## POWER SUPPLY OPTIONS

A.



A. Battery Pack - 24V and 36V Battery packs are equipped with gelled electrolyte batteries. This allows the batteries to be shipped and stored in any position without spillage of corrosive materials. Batteries should not be totally discharged before charging or they may refuse to accept a charge. Charge when performance begins to fade and also before putting battery pack into storage. **Charge only with the charger supplied with the unit.** The operator can expect 3-4 hours of pumping time before batteries need charged overnight (approximately 16 hours). Avoid leaving batteries on the charger for an extended time. The batteries do not develop a full storage capacity until after approximately 25 charge/discharge cycles have been completed. If the above cautions are followed, the operator can expect 250 to 500 cycles from these batteries.

B.



C.



D.



E.



B. 110V Power Supply - Inputs 110V AC and outputs 36V DC required to run the pump. Use this with any 110V power source (110V generator, 110V wall outlet, etc.) No maintenance is required for this power supply.

C. Portable Power Supply Control Case - This briefcase also inputs 110V AC and outputs the 36V DC required to run the pump. Use with any 110V power source (110V generator, 110V wall outlet, etc.) or plug a 36V Battery Pack into the DC jack. No maintenance is required for this power supply.

D. 110V Stand Alone Power Supply Control Box -inputs 110V AC and outputs the 36V DC required to run the pump. Use with any 110V power source (110V generator, 110V wall outlet, etc.) No maintenance is required for this power supply.

E. 12V Power Supply - For use when powering the pump system from an automobile battery. Attach the alligator clips to the vehicle's battery terminals (be sure to match polarity). Use an extension cord (<50' recommended) to go from the vehicle battery to the well head. Plug one of the other power supplies (B, C, or D above) into the extension cord. Be sure the cooling fan on this unit is exposed.